

ETA 4 1450 r.p.m

تیپ پمپ	قدرت		جریان A	قطر پروانه D (mm)	قطر فلانچ پمپ (mm)		اندهی (m ³ /h)	50	75	100	125	150	175	200	225	235	250	260	275	300	330	
	KW	HP			رانش	مکش		36	35.5	34.8	33.1	31	27.2	23	17.2	15	*	*	*	*	*	*
ETA4 125-400 F	22	30	43.5	320	125	150	H (m)	36	35.5	34.8	33.1	31	27.2	23	17.2	15	*	*	*	*	*	
ETA4 125-400 E	30	41	58	340	125	150		41	40.9	40.3	38.9	37	34	30.5	25	22.2	18	15	*	*	*	*
ETA4 125-400 D	37	50	71	360	125	150		46	45.5	45	43.8	42.2	39.9	37.2	32.8	30.5	26.5	23	18	*	*	*
ETA4 125-400 C	45	60	87	380	125	150		51	50.5	50	49	48	45.9	43.6	40.5	38.8	35.5	32.9	28	20	*	*
ETA4 125-400 B	55	75	104	400	125	150		56.5	56	55.5	54.6	53.5	51.8	50	47	45.8	43.8	42	38.7	32	22.5	22.5
ETA4 125-400 A	55	75	104	404	125	150		58	57.5	57	56	55	53.5	51.7	48.8	47.6	45.5	44	40.6	34	24.5	24.5

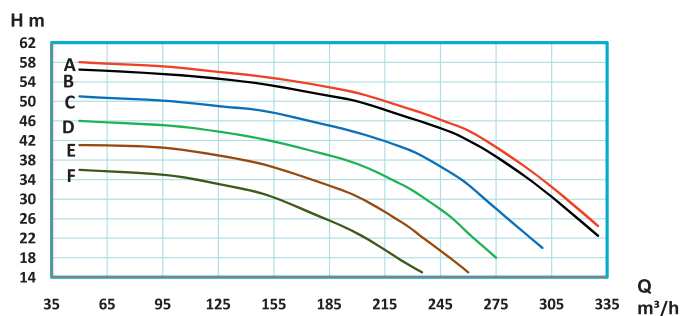

تیپ پمپ	قدرت		جریان A	قطر پروانه D (mm)	قطر فلانچ پمپ (mm)		اندهی (m ³ /h)	100	150	200	225	250	275	300	325	350	375	400	410	420	425
	KW	HP			رانش	مکش		6	5.7	5.3	5	4.7	4.3	*	*	*	*	*	*	*	*
ETA4 150-200 G	5.5	7.5	12	190/110	150	200	H (m)	6	5.7	5.3	5	4.7	4.3	*	*	*	*	*	*	*	*
ETA4 150-200 F	7.5	10	16	200/130	150	200		7.2	6.9	6.5	6.3	6	5.7	5.3	4.9	*	*	*	*	*	*
ETA4 150-200 E	7.5	10	16	200/150	150	200		8.3	7.9	7.5	7.2	6.9	6.5	6.1	5.7	5.3	*	*	*	*	*
ETA4 150-200 D	11	15	22	209/156	150	200		9.2	8.8	8.3	8	7.7	7.3	6.9	6.4	5.8	*	*	*	*	*
ETA4 150-200 C	11	15	22	209/190	150	200		10.7	10.3	9.7	9.4	9	8.6	8.1	7.5	7	6.3	5.5	5.2	*	*
ETA4 150-200 B	11	15	22	209/200	150	200		11.9	11.4	10.7	10.3	9.9	9.4	9	8.4	7.7	7.1	6.4	6.1	*	*
ETA4 150-200 A	15	20	29	209	150	200	13.2	12.6	11.8	11.3	10.8	10.3	9.7	9.1	8.5	7.9	7.2	6.9	6.6	6.4	6.4

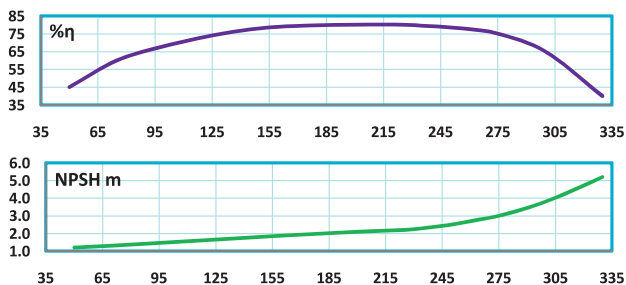
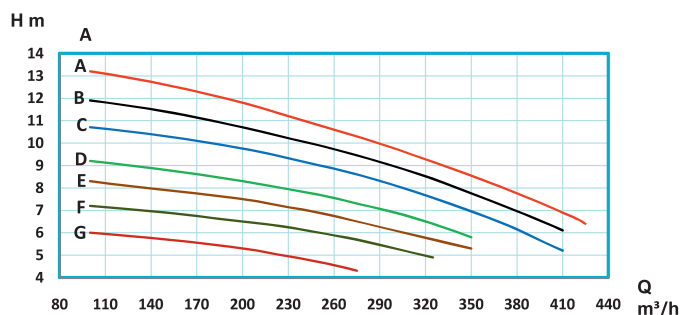
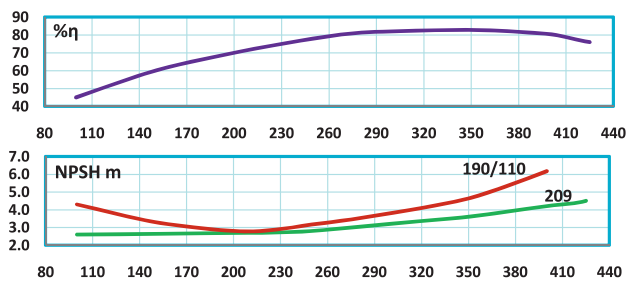

تیپ پمپ	قدرت		جریان A	قطر پروانه D (mm)	قطر فلانچ پمپ (mm)		اندهی (m ³ /h)	100	150	200	250	300	325	350	375	400	425	450	475	500	510
	KW	HP			رانش	مکش		12.5	12.1	11.5	10.7	9.5	8.8	8	7.2	*	*	*	*	*	*
ETA4 150-250 F	11	15	22	225/176	150	200	H (m)	12.5	12.1	11.5	10.7	9.5	8.8	8	7.2	*	*	*	*	*	*
ETA4 150-250 E	15	20	29	235/207	150	200		15.3	14.9	14.4	13.5	12.3	11.6	10.8	10	9.2	8.2	*	*	*	*
ETA4 150-250 D	18.5	25	38	240/223	150	200		16.9	16.5	16	15	13.8	13.1	12.4	11.6	10.7	9.7	*	*	*	*
ETA4 150-250 C	18.5	25	38	245/235	150	200		18.2	17.8	17.3	16.5	15.4	14.8	14	13.1	12.2	11.3	10.4	*	*	*
ETA4 150-250 B	22	30	43.5	250	150	200		19.7	19.5	19	18.2	17.2	16.5	15.8	15	14.1	13.2	12.2	11	*	*
ETA4 150-250 A	30	41	58	259	150	200		21.3	21.2	20.8	20.1	19.2	18.6	18	17.3	16.5	15.6	14.6	13.6	12.5	12

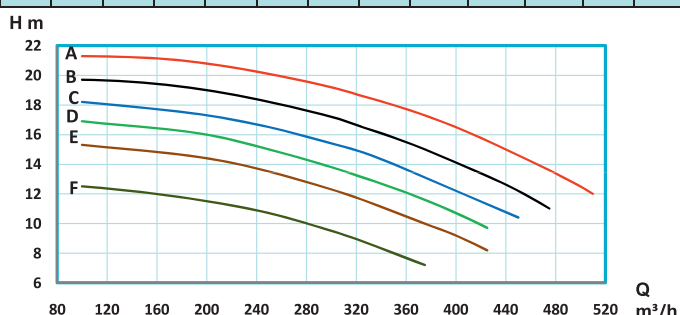
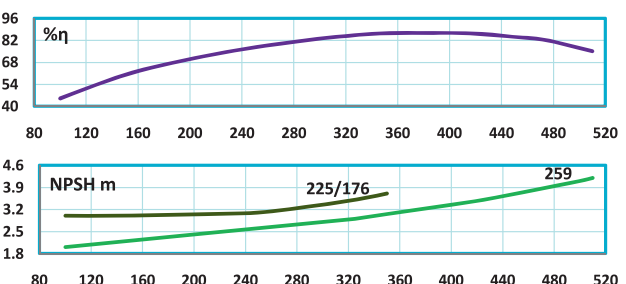

ETA 2900 r.p.m

تیپ پمپ	قدرت		جریان A	قطر پروانه D (mm)	قطر فلانج پمپ (mm)		آبدهی (m ³ /h)	50	100	125	150	175	200	225	250	270	275	300	325	350	380
	KW	HP			رانس	مکش		50	100	125	150	175	200	225	250	270	275	300	325	350	380
ETA 100-200 E	30	41	57	170	100	125	H (m)	37	36	35	33.9	32.4	30.2	27.5	24	21	20	*	*	*	*
ETA 100-200 D	37	50	69	180	100	125		42.5	42	41.2	40.2	38.7	36.5	33.7	30.9	27.9	27	22.6	*	*	*
ETA 100-200 C	45	60	83	190	100	125		47.1	46.6	46.1	45.3	44.1	42.3	40	37.4	34.9	34.2	30	25	*	*
ETA 100-200 B	55	75	104	200	100	125		53.5	52.9	52.3	51.5	50.6	49	47	44.8	42.8	42.2	38.6	34.5	29.1	*
ETA 100-200 A	55	75	104	209	100	125		59.5	59	58.7	58.2	57.4	56.2	54.8	52.8	50.9	50.3	47	42.8	37.6	30.9

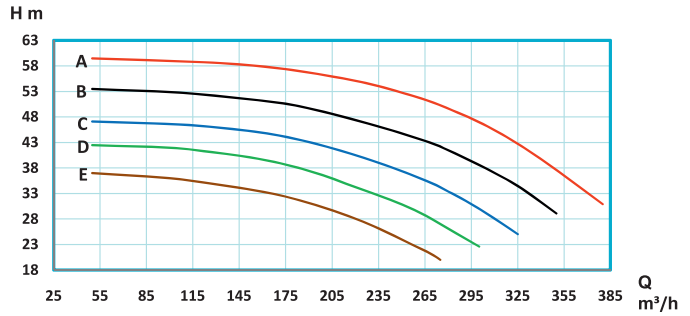
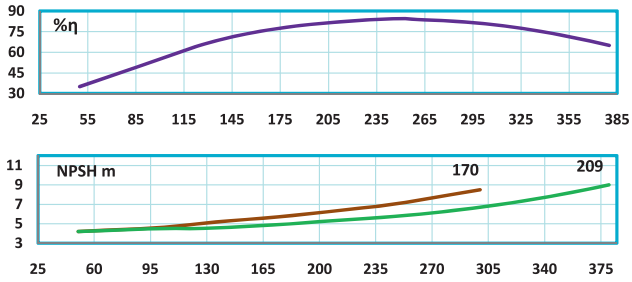

تیپ پمپ	قدرت		جریان A	قطر پروانه D (mm)	قطر فلانج پمپ (mm)		آبدهی (m ³ /h)	50	100	125	150	175	200	225	250	260	275	300	325	350	390
	KW	HP			رانس	مکش		50	100	125	150	175	200	225	250	260	275	300	325	350	390
ETA 100-250 E	45	60	83	220	100	125	H (m)	64	63	61.8	59.5	56	51.5	45.3	38.3	35.3	30	*	*	*	*
ETA 100-250 D	55	75	104	230	100	125		70.8	69	68	66	63	59.5	54.3	48.3	45.5	41	33.1	*	*	*
ETA 100-250 C	75	100	140	240	100	125		77	75.1	74	72.9	70.3	67	62.7	57.8	55.6	51.7	45	37	*	*
ETA 100-250 B	75	100	140	250	100	125		84	82.1	81	79.8	77.9	75.6	72	67	65	61.3	55.1	47.6	40	*
ETA 100-250 A	90	122	166	259	100	125		90	89	88	86.9	85.1	82.9	80	76.3	74.5	71.9	66.8	60	53	40

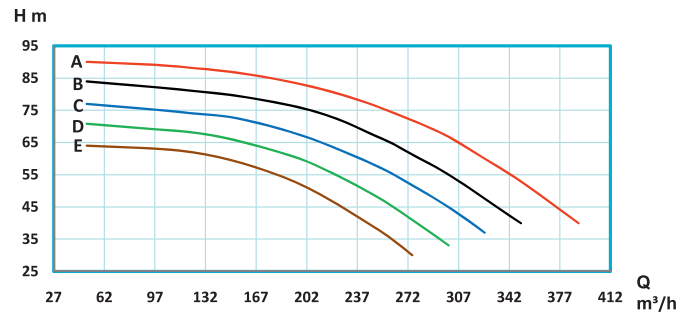
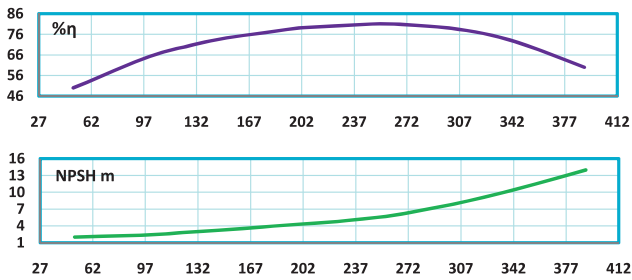

تیپ پمپ	قدرت		جریان A	قطر پروانه D (mm)	قطر فلانج پمپ (mm)		آبدهی (m ³ /h)	100	150	175	200	225	250	275	300	325	350	400	425	450	490
	KW	HP			رانس	مکش		100	150	175	200	225	250	275	300	325	350	400	425	450	490
ETA 125-200 E	37	50	69	170	125	150	H (m)	36.5	36	35.5	34.7	33.5	31.8	29.6	27.2	24	*	*	*	*	*
ETA 125-200 D	45	60	83	180	125	150		41	40.5	40	39.5	38.8	37.8	36	33.5	31	28.5	*	*	*	*
ETA 125-200 C	55	75	104	190	125	150		45.6	45.1	45	44.6	44	43.2	42	40	37.5	35	30	*	*	*
ETA 125-200 B	75	100	140	200	125	150		50.4	50.1	50	49.8	49.4	48.8	48	46.5	44.6	42.6	38.3	35.7	32.45	*
ETA 125-200 A	75	100	140	209	125	150		55.3	55	54.7	54.5	54	53.5	53	52.1	50.8	49	45.3	42.8	40.3	36

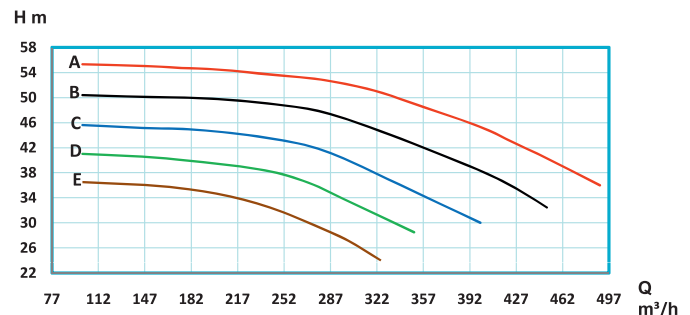
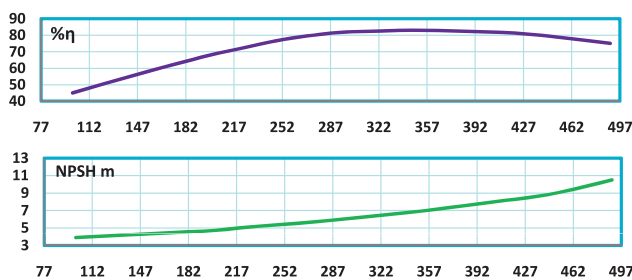

80-100
125-200 & 125-250
150-200 & 150-250 & 150-315 & 150-400

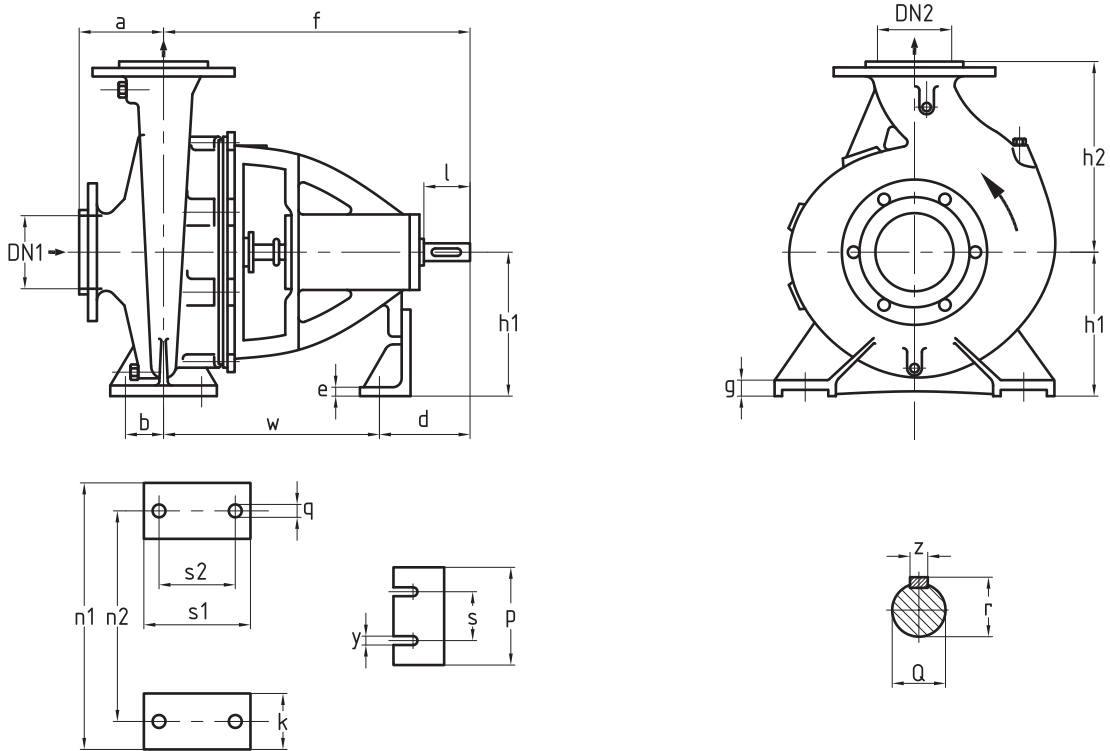

TYPE	mm																							
	DN1	DN2	a	f	h1	h2	l	w	b	d	e	g	n1	n2	q	s1	s2	k	p	s	y	Q	z	r
ETA 80-160				360	180	225	50	265	47.5	95		17	320	250	14	125	95	65				24	8	26.9
ETA 80-200						250					8		345	280										
ETA 80-250	100	80	125	470	200	280	80	340	80	130			400	315					160	110	14	32	10	35.3
ETA 80-315					250	315						18			18	160	120	80						
ETA 80-400				530	280	355	110	370	60	160			435	355								42	12	45.1
ETA 100-160	125	100	125	470	200	280	80	340	60	130	8	18	360	280	18	160	120	80	160	110	14	32	10	35.3
ETA 100-200																								
ETA 100-250				470	225	280	80	340	60	130	8	18	400	315	18	160	120	80				32	10	35.3
ETA 100-315	125	100	140		250	315													160	110	14			
ETA 100-400				530	280	355	110	370	75	160	12	20	500	400	23	200	150	100				42	12	45.1
ETA 125-200						315			80		12													
ETA 125-250	150	125	140	470	250		80	340	60	130	17	18	400	315	18	160	120	80	160	110	14	32	10	35.3
ETA 150-200				470			80	340		130			550	450										
ETA 150-250					280	400							500	400								32	10	35.3
ETA 150-315	200	150	160						75		12	20			23	200	150	100	160	110	14			
ETA 150-400				530			110	370		160			550	450								42	12	45.1
					315	450																		